

ACTUAL FLANGE WIDTH SETTING (IN)	3.50	4.90	5.70	6.90	7.70	8.90	9.85	10.80	12.05	12.80	13.78	14.80	15.75	16.70	17.75	18.70	19.70
MINIMUM HEADROOM DIMENSION "A" (IN)	26.57	26.50	26.46	26.76	26.97	27.65	28.19	28.80	29.61	30.51	31.69	32.92	34.06	35.20	36.46	37.59	38.78

FLANGE ADJUSTMENT RANGES
3.500" - 5.700"
5.701" - 7.700"
7.701" - 9.850"
9.851" - 12.050"
12.051" - 13.780"
13.781" - 15.750"
15.751" - 17.750"
17.751" - 19.700"

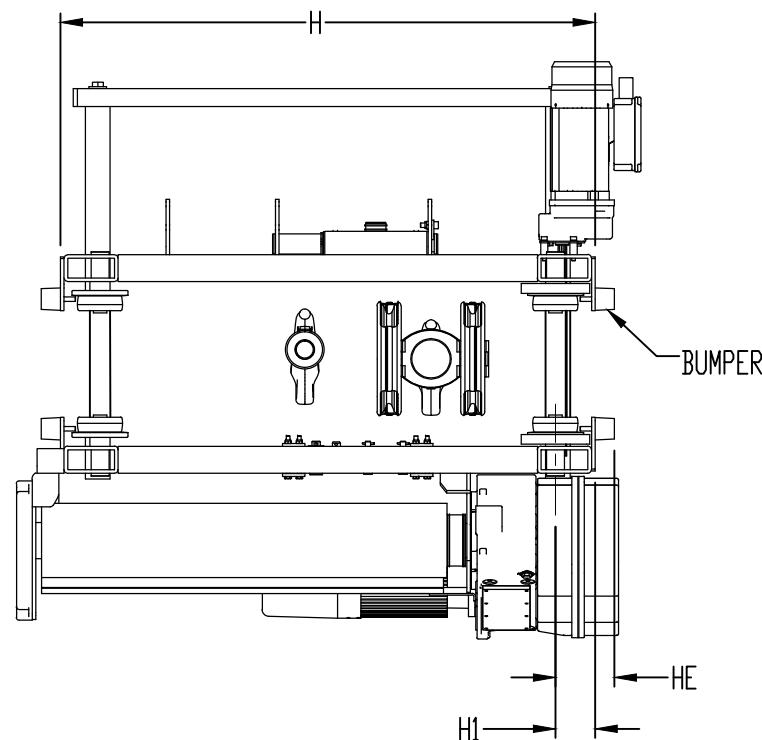

TECHNICAL DATA	
HOIST PLATFORM	GN WIRE ROPE HOIST
HOIST MODEL NUMBER	YKB-L05-033S420-2
RATED LIFT CAPACITY	5 U.S. TON
ACTUAL LIFT DISTANCE	33 FT (10.1 M)
MAXIMUM LIFTING SPEED	20 FT/MIN (6.1 M/MIN)
REEVING STYLE	4-PART SINGLE-REEVED
HOIST CONTROL TYPE	TWO-SPEED
HOIST SUSPENSION TYPE	UNDERHUNG MOTORIZED TROLLEY
TROLLEY TRAVERSE SPEED	80 FT/MIN (24.38 M/MIN)
TROLLEY CONTROL TYPE	TWO-SPEED
TROLLEY BUMPERS	INCLUDED
HOIST DUTY CLASSIFICATION	H4/M5
OPERATING VOLTAGE	460V/3PH/60HZ
CONTROL VOLTAGE	120VAC
HOIST MOTOR (MAIN) HP	7.80
TROLLEY MOTOR HP	0.6
TROLLEY MOTOR QTY	1
BASE WEIGHT OF HOIST (LBS)	786.83

DIMENSIONAL DATA	
B	30.99 INCH
C	21.83 INCH
D*	24.13 INCH
E*	24.70 INCH
Q	13.53 INCH
W*	26.50 INCH
WTD	3.94 INCH
WB	39.96 INCH
H	46.89 INCH
H1	3.54 INCH
HE	5.08 INCH
XB	1.54 INCH
AP	15.79 INCH
AQ	7.20 INCH

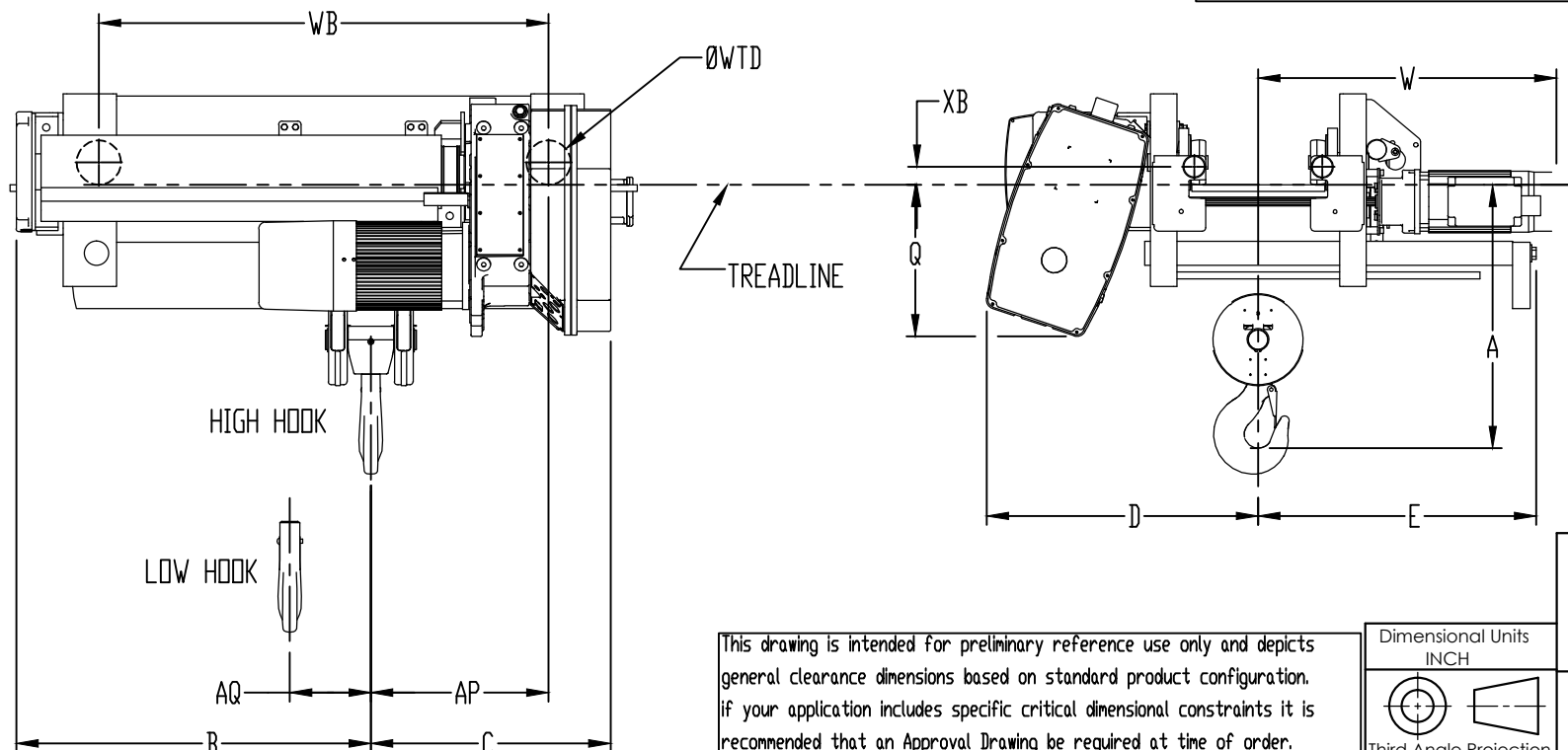

This drawing is intended for preliminary reference use only and depicts general clearance dimensions based on standard product configuration. If your application includes specific critical dimensional constraints it is recommended that an Approval Drawing be required at time of order.

Dimensional Units INCH	
	Third Angle Projection

2-SPEED

Description:
CLEARANCE DIAGRAM
5 TON 33 FT LIFT S4 REEVING 20 FT/MIN

NOTE:

* DIMENSIONS D, E, AND W ARE SHOWN FOR A BEAM FLANGE WIDTH 8.00 INCHES. THESE DIMENSIONS ARE MEASURED FROM CAD MODELS AND CONSIDERED AS APPROXIMATE VALUES.

Modeled:	05/08/2018	SRCCE
Drawn:	05/08/2018	SRCCE
Approved:		
Design Authority:	-	
Original project:	-	
Original Scale:	1:16	

Format	Number:	Sheet
B	YKB-L05-033S420-2	1

ECN	Rev.	Description of change	Date	By
-	-	-	-	-
-	-	-	-	-
-	-	-	-	-

ACTUAL FLANGE WIDTH SETTING (IN)	3.50	4.90	5.70	6.90	7.70	8.90	9.85	10.80	12.05	12.80	13.78	14.80	15.75	16.70	17.75	18.70	19.70
MINIMUM HEADROOM DIMENSION "A" (IN)	26.57	26.50	26.46	26.76	26.97	27.65	28.19	28.80	29.61	30.51	31.69	32.92	34.06	35.20	36.46	37.59	38.78

FLANGE ADJUSTMENT RANGES
3.500" - 5.700"
5.701" - 7.700"
7.701" - 9.850"
9.851" - 12.050"
12.051" - 13.780"
13.781" - 15.750"
15.751" - 17.750"
17.751" - 19.700"

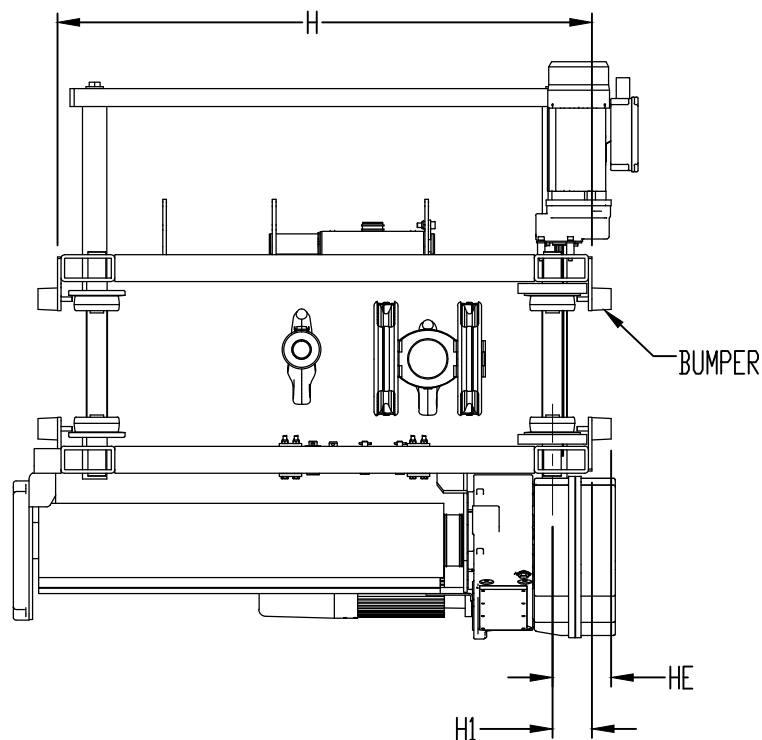

TECHNICAL DATA	
HOIST PLATFORM	GN WIRE ROPE HOIST
HOIST MODEL NUMBER	YKB-L05-033S420-V
RATED LIFT CAPACITY	5 U.S. TON
ACTUAL LIFT DISTANCE	33 FT (10.1 M)
MAXIMUM LIFTING SPEED	20 FT/MIN (6.1 M/MIN)
REEVING STYLE	4-PART SINGLE-REEVED
HOIST CONTROL TYPE	VARIABLE SPEED
HOIST SUSPENSION TYPE	UNDERHUNG MOTORIZED TROLLEY
TROLLEY TRAVERSE SPEED	80 FT/MIN (24.38 M/MIN)
TROLLEY CONTROL TYPE	TWO-SPEED
TROLLEY BUMPERS	INCLUDED
HOIST DUTY CLASSIFICATION	H4/M5
OPERATING VOLTAGE	460V/3PH/60HZ
CONTROL VOLTAGE	120VAC
HOIST MOTOR (MAIN) HP	7.80
TROLLEY MOTOR HP	0.6
TROLLEY MOTOR QTY	1
BASE WEIGHT OF HOIST (LBS)	786.83

DIMENSIONAL DATA	
B	30.99 INCH
C	21.83 INCH
D*	24.13 INCH
E*	24.15 INCH
E1*	34.59 INCH
Q	13.53 INCH
W*	26.50 INCH
WTD	3.94 INCH
WB	39.96 INCH
H	46.89 INCH
H1	3.54 INCH
HE	5.08 INCH
XB	1.54 INCH
AP	15.79 INCH
AQ	7.20 INCH

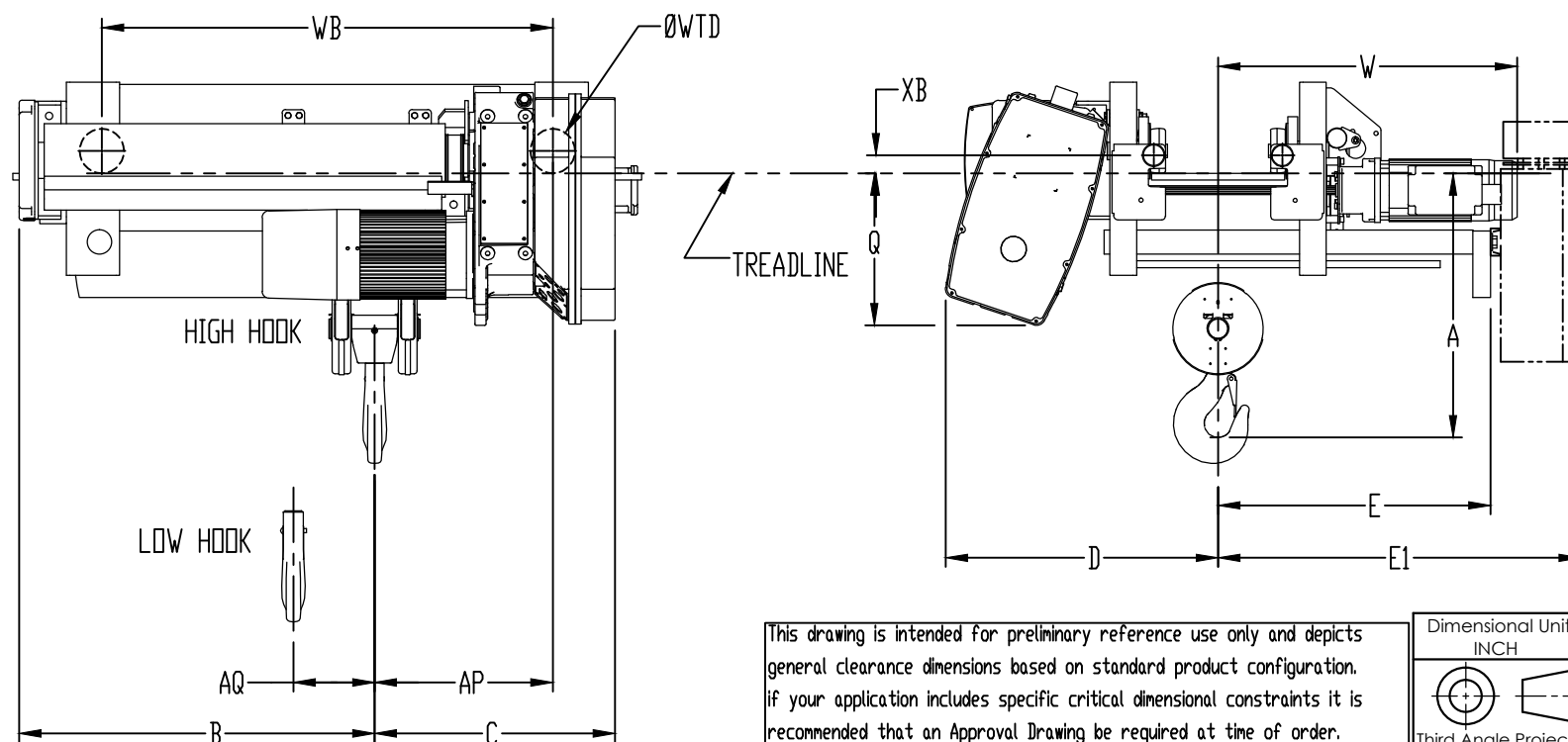

This drawing is intended for preliminary reference use only and depicts general clearance dimensions based on standard product configuration. If your application includes specific critical dimensional constraints it is recommended that an Approval Drawing be required at time of order.

Dimensional Units
INCH

Third Angle Projection

VARIABLE SPEED

Description:
CLEARANCE DIAGRAM
5 TON 33 FT LIFT S4 REEVING 20 FT/MIN

Modeled:	11/26/2018	SRCCE
Drawn:	11/26/2018	SRCCE
Approved:		
Design Authority:		
Original project:		
Original Scale:	1:16	

Format	Number:	Sheet
B	YKB-L05-033S420-V	2

NOTE:

* DIMENSIONS D, E, E1 AND W ARE SHOWN FOR A BEAM FLANGE WIDTH 8.00 INCHES. THESE DIMENSIONS ARE MEASURED FROM CAD MODELS AND CONSIDERED AS APPROXIMATE VALUES.

ECN	Rev.	Description of change	Date	By
-	-	-	-	-
-	-	-	-	-
-	-	-	-	-