

|                                     |       |       |       |       |       |       |       |       |       |       |       |       |       |       |       |       |       |
|-------------------------------------|-------|-------|-------|-------|-------|-------|-------|-------|-------|-------|-------|-------|-------|-------|-------|-------|-------|
| ACTUAL FLANGE WIDTH SETTING (IN)    | 3.50  | 4.90  | 5.70  | 6.90  | 7.70  | 8.90  | 9.85  | 10.80 | 12.05 | 12.80 | 13.78 | 14.80 | 15.75 | 16.70 | 17.75 | 18.70 | 19.70 |
| MINIMUM HEADROOM DIMENSION "A" (IN) | 30.91 | 31.28 | 31.50 | 32.58 | 33.31 | 34.71 | 35.83 | 36.97 | 38.46 | 39.37 | 40.55 | 41.77 | 42.91 | 44.11 | 45.43 | 46.60 | 47.83 |

| FLANGE ADJUSTMENT RANGES |
|--------------------------|
| 3.500' - 5.700'          |
| 5.701' - 7.700'          |
| 7.701' - 9.850'          |
| 9.851' - 12.050'         |
| 12.051' - 13.780'        |
| 13.781' - 15.750'        |
| 15.751' - 17.750'        |
| 17.751' - 19.700'        |

| DIMENSIONAL DATA |            |
|------------------|------------|
| B                | 33.55 INCH |
| C                | 19.27 INCH |
| D*               | 24.13 INCH |
| E*               | 24.70 INCH |
| Q                | 13.53 INCH |
| W*               | 26.50 INCH |
| WTD              | 3.94 INCH  |
| WB               | 39.96 INCH |
| H                | 46.89 INCH |
| H1               | 3.54 INCH  |
| HE               | 5.08 INCH  |
| XB               | 1.54 INCH  |
| AP               | 13.23 INCH |
| AQ               | 14.45 INCH |

NOTE:

\* DIMENSIONS D, E, AND W ARE SHOWN FOR A BEAM FLANGE WIDTH 8.00 INCHES. THESE DIMENSIONS ARE MEASURED FROM CAD MODELS AND CONSIDERED AS APPROXIMATE VALUES.

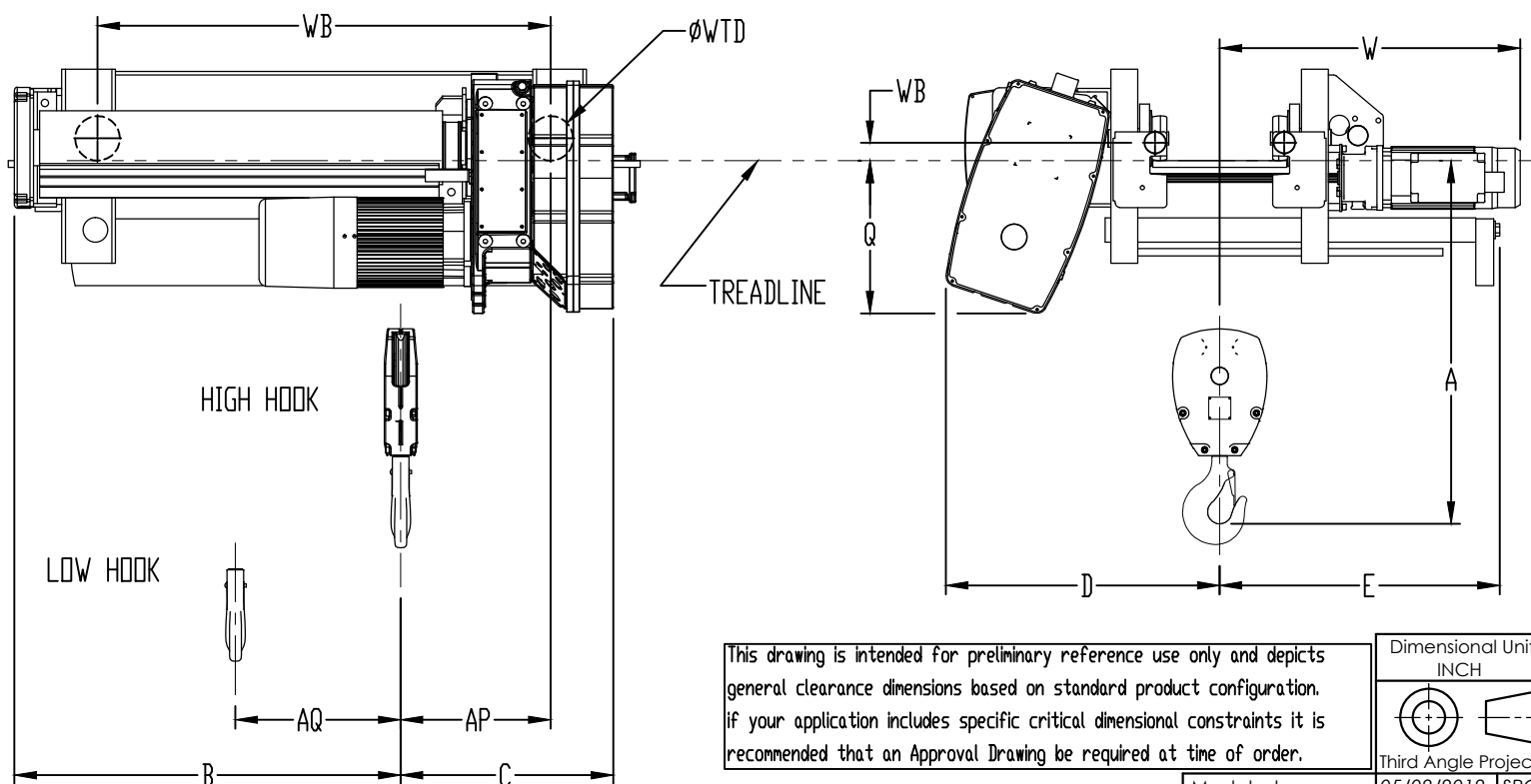
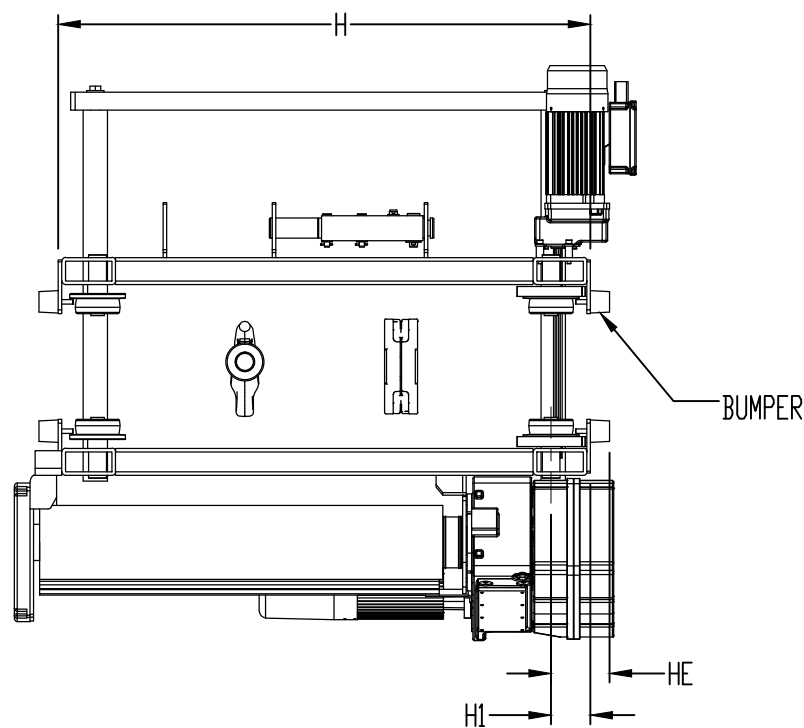

| TECHNICAL DATA             |                             |
|----------------------------|-----------------------------|
| HOIST PLATFORM             | GN WIRE ROPE HOIST          |
| HOIST MODEL NUMBER         | YKB-L03-066S231-2           |
| RATED LIFT CAPACITY        | 3 U.S. TON                  |
| ACTUAL LIFT DISTANCE       | 66 FT (20.1 M)              |
| MAXIMUM LIFTING SPEED      | 31 FT/MIN (9.4 M/MIN)       |
| REEVING STYLE              | 2-PART SINGLE-REEVED        |
| HOIST CONTROL TYPE         | TWO-SPEED                   |
| HOIST SUSPENSION TYPE      | UNDERHUNG MOTORIZED TROLLEY |
| TROLLEY TRAVERSE SPEED     | 80 FT/MIN (24.38 M/MIN)     |
| TROLLEY CONTROL TYPE       | TWO-SPEED                   |
| TROLLEY BUMPERS            | INCLUDED                    |
| HOIST DUTY CLASSIFICATION  | H4/M5                       |
| OPERATING VOLTAGE          | 460V/3PH/60Hz               |
| CONTROL VOLTAGE            | 120VAC                      |
| HOIST MOTOR (MAIN) HP      | 7.80                        |
| TROLLEY MOTOR HP           | 0.6                         |
| TROLLEY MOTOR QTY          | 1                           |
| BASE WEIGHT OF HOIST (LBS) | 731.73                      |

This drawing is intended for preliminary reference use only and depicts general clearance dimensions based on standard product configuration. If your application includes specific critical dimensional constraints it is recommended that an Approval Drawing be required at time of order.

Dimensional Units  
INCH

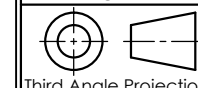

Third Angle Projection

|                   |            |       |
|-------------------|------------|-------|
| Modeled:          | 05/08/2018 | SRCCE |
| Drawn:            | 05/08/2018 | SRCCE |
| Approved:         |            |       |
| Design Authority: |            |       |
| Original project: |            |       |
| Original Scale:   | 1:16       |       |

**2-SPEED**

Description:  
**CLEARANCE DIAGRAM**  
3 TON 66 FT LIFT S2 REEVING 31 FT/MIN

|          |                          |          |
|----------|--------------------------|----------|
| Format   | Number:                  | Sheet    |
| <b>B</b> | <b>YKB-L03-066S231-2</b> | <b>1</b> |

| ECN | Rev. | Description of change | Date | By |
|-----|------|-----------------------|------|----|
| -   | -    | -                     | -    | -  |
| -   | -    | -                     | -    | -  |
| -   | -    | -                     | -    | -  |

|                                     |       |       |       |       |       |       |       |       |       |       |       |       |       |       |       |       |       |
|-------------------------------------|-------|-------|-------|-------|-------|-------|-------|-------|-------|-------|-------|-------|-------|-------|-------|-------|-------|
| ACTUAL FLANGE WIDTH SETTING (IN)    | 3.50  | 4.90  | 5.70  | 6.90  | 7.70  | 8.90  | 9.85  | 10.80 | 12.05 | 12.80 | 13.78 | 14.80 | 15.75 | 16.70 | 17.75 | 18.70 | 19.70 |
| MINIMUM HEADROOM DIMENSION "A" (IN) | 30.91 | 31.28 | 31.50 | 32.58 | 33.31 | 34.71 | 35.83 | 36.97 | 38.46 | 39.37 | 40.55 | 41.77 | 42.91 | 44.11 | 45.43 | 46.60 | 47.83 |

| FLANGE ADJUSTMENT RANGES |
|--------------------------|
| 3.500' - 5.700'          |
| 5.701' - 7.700'          |
| 7.701' - 9.850'          |
| 9.851' - 12.050'         |
| 12.051' - 13.780'        |
| 13.781' - 15.750'        |
| 15.751' - 17.750'        |
| 17.751' - 19.700'        |

| DIMENSIONAL DATA |            |
|------------------|------------|
| B                | 33.55 INCH |
| C                | 19.27 INCH |
| D*               | 24.13 INCH |
| E*               | 24.15 INCH |
| E1*              | 34.59 INCH |
| Q                | 13.53 INCH |
| W*               | 26.50 INCH |
| WTD              | 3.94 INCH  |
| WB               | 39.96 INCH |
| H                | 46.89 INCH |
| H1               | 3.54 INCH  |
| HE               | 5.08 INCH  |
| XB               | 1.54 INCH  |
| AP               | 13.23 INCH |
| AQ               | 14.45 INCH |

NOTE:

\* DIMENSIONS D, E, E1 AND W ARE SHOWN FOR A BEAM FLANGE WIDTH 8.00 INCHES. THESE DIMENSIONS ARE MEASURED FROM CAD MODELS AND CONSIDERED AS APPROXIMATE VALUES.

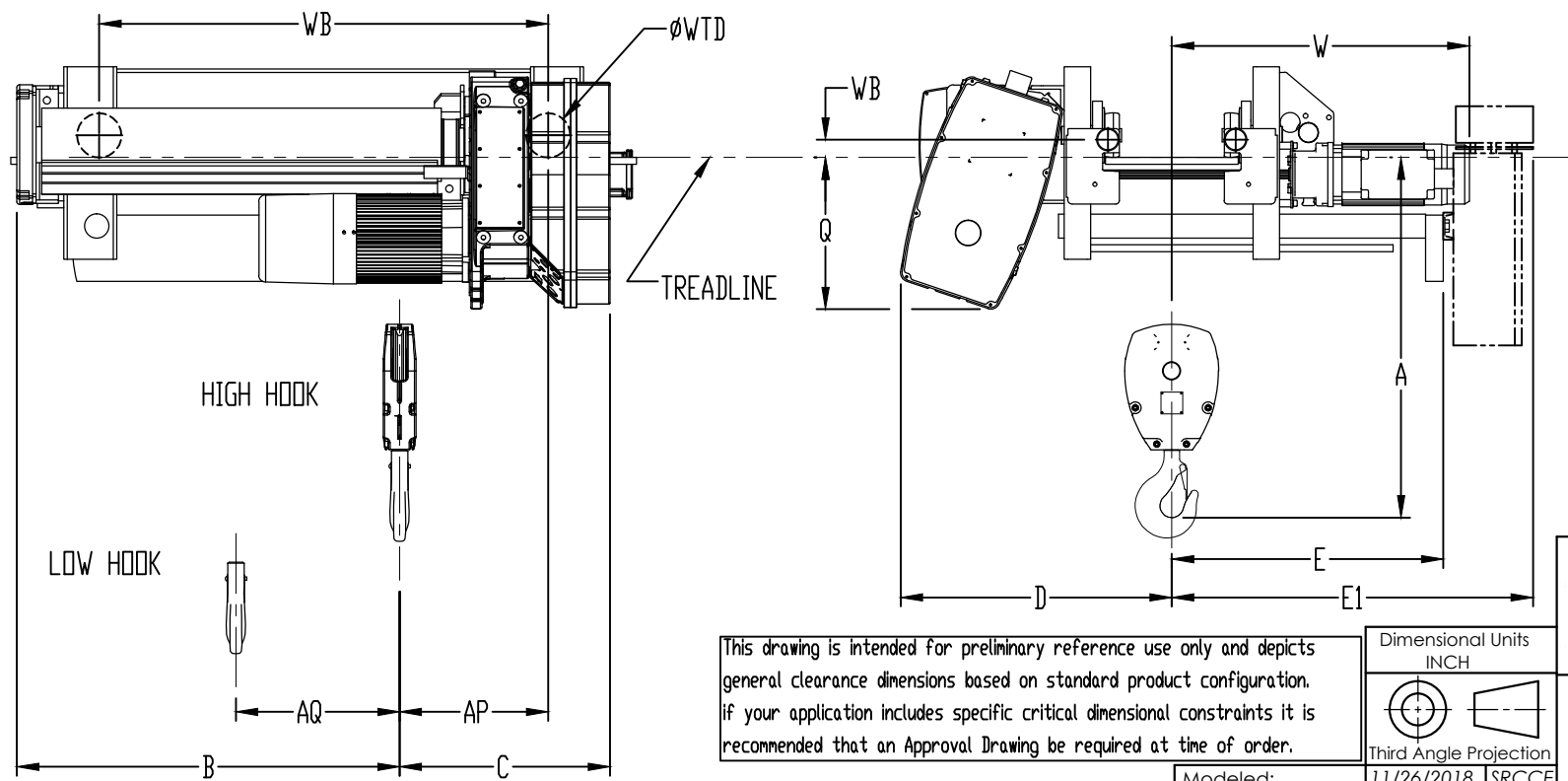
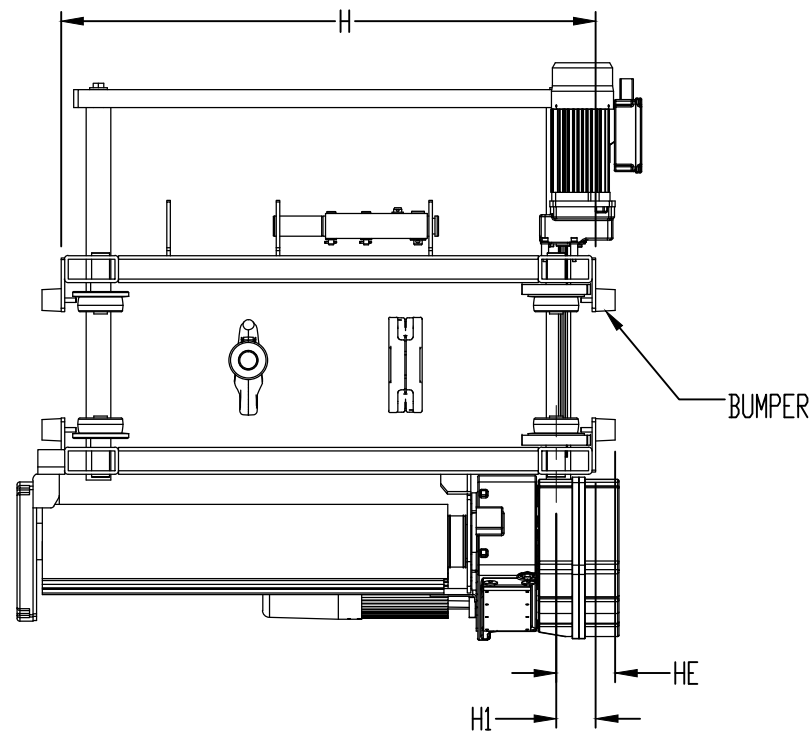

| TECHNICAL DATA             |                             |
|----------------------------|-----------------------------|
| HOIST PLATFORM             | GN WIRE ROPE HOIST          |
| HOIST MODEL NUMBER         | YKB-L03-066S231-V           |
| RATED LIFT CAPACITY        | 3 U.S. TON                  |
| ACTUAL LIFT DISTANCE       | 66 FT (20.1 M)              |
| MAXIMUM LIFTING SPEED      | 31 FT/MIN (9.4 M/MIN)       |
| REEVING STYLE              | 2-PART SINGLE-REEVED        |
| HOIST CONTROL TYPE         | VARIABLE SPEED              |
| HOIST SUSPENSION TYPE      | UNDERHUNG MOTORIZED TROLLEY |
| TROLLEY TRAVERSE SPEED     | 80 FT/MIN (24.38 M/MIN)     |
| TROLLEY CONTROL TYPE       | TWO-SPEED                   |
| TROLLEY BUMPERS            | INCLUDED                    |
| HOIST DUTY CLASSIFICATION  | H4/M5                       |
| OPERATING VOLTAGE          | 460V/3PH/60Hz               |
| CONTROL VOLTAGE            | 120VAC                      |
| HOIST MOTOR (MAIN) HP      | 7.80                        |
| TROLLEY MOTOR HP           | 0.6                         |
| TROLLEY MOTOR QTY          | 1                           |
| BASE WEIGHT OF HOIST (LBS) | 731.73                      |

This drawing is intended for preliminary reference use only and depicts general clearance dimensions based on standard product configuration. If your application includes specific critical dimensional constraints it is recommended that an Approval Drawing be required at time of order.

Dimensional Units  
INCH

Third Angle Projection

|                   |            |      |
|-------------------|------------|------|
| Modeled:          | 11/26/2018 | SRCC |
| Drawn:            | 11/26/2018 | SRCC |
| Approved:         |            |      |
| Design Authority: |            |      |
| Original project: |            |      |
| Original Scale:   | 1:16       |      |

**VARIABLE SPEED**

Description:  
**CLEARANCE DIAGRAM**  
3 TON 66 FT LIFT S2 REEVING 31 FT/MIN

|          |                          |          |
|----------|--------------------------|----------|
| Format   | Number:                  | Sheet    |
| <b>B</b> | <b>YKB-L03-066S231-V</b> | <b>2</b> |

| ECN | Rev. | Description of change | Date | By |
|-----|------|-----------------------|------|----|
| -   | -    | -                     | -    | -  |
| -   | -    | -                     | -    | -  |
| -   | -    | -                     | -    | -  |