

ACTUAL FLANGE WIDTH SETTING (IN)	3.25	4.90	5.70	6.90	7.70	8.90	9.85	10.80	12.05	12.80	13.78	14.80	15.75	16.70	17.75	18.70	19.70
MINIMUM HEADROOM DIMENSION "A" (IN)	28.35	29.17	29.57	31.01	31.97	33.42	34.57	35.74	37.28	38.19	39.37	40.59	41.73	42.87	44.13	45.27	46.46

FLANGE ADJUSTMENT RANGES
3.248" - 5.700"
5.701" - 7.700"
7.701" - 9.850"
9.851" - 12.050"
12.051" - 13.780"
13.781" - 15.750"
15.751" - 17.750"
17.751" - 19.700"

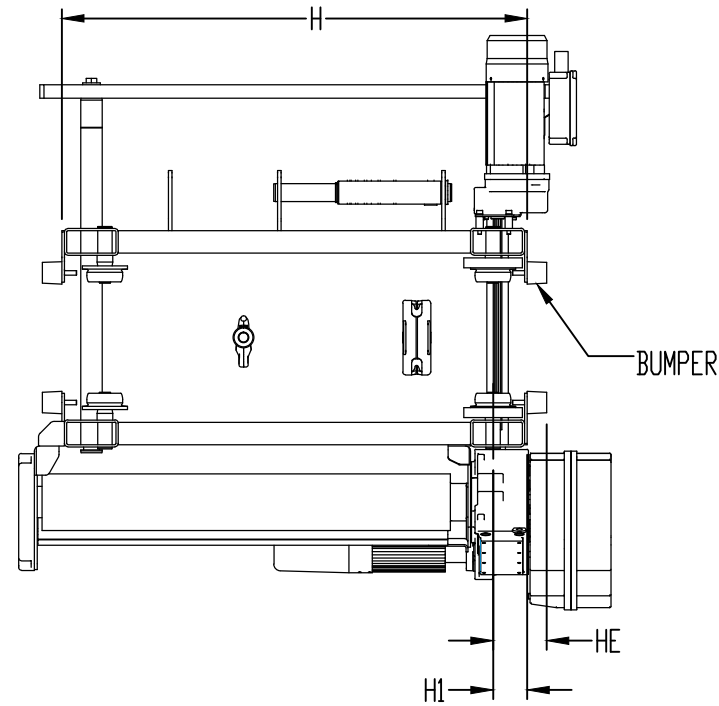

TECHNICAL DATA	
HOIST PLATFORM	GN WIRE ROPE HOIST
HOIST MODEL NUMBER	YKA-L01-066S239-2
RATED LIFT CAPACITY	1 U.S. TON
ACTUAL LIFT DISTANCE	66FT (20.1M)
MAXIMUM LIFTING SPEED	39 FT/MIN (11.9 M/MIN)
REEVING STYLE	2-PART SINGLE-REEVED
HOIST CONTROL TYPE	TWO-SPEED
HOIST SUSPENSION TYPE	UNDERHUNG MOTORIZED TROLLEY
TROLLEY TRAVERSE SPEED	80 FT/MIN (24.38 M/MIN)
TROLLEY CONTROL TYPE	TWO-SPEED
TROLLEY BUMPERS	INCLUDED
HOIST DUTY CLASSIFICATION	H4+/M6
OPERATING VOLTAGE	460V/3PH/60Hz
CONTROL VOLTAGE	120VAC
HOIST MOTOR (MAIN) HP	3.90
TROLLEY MOTOR HP	0.6
TROLLEY MOTOR QTY	1
BASE WEIGHT OF HOIST (LBS)	617.12

DIMENSIONAL DATA	
B	34.92 INCH
C	17.30 INCH
D*	23.87 INCH
E*	22.74 INCH
Q	13.89 INCH
W*	26.50 INCH
WTD	3.15 INCH
WB	34.05 INCH
H	40.83 INCH
H1	2.99 INCH
HE	4.69 INCH
XB	1.57 INCH
AP	6.69 INCH
AQ	15.20 INCH

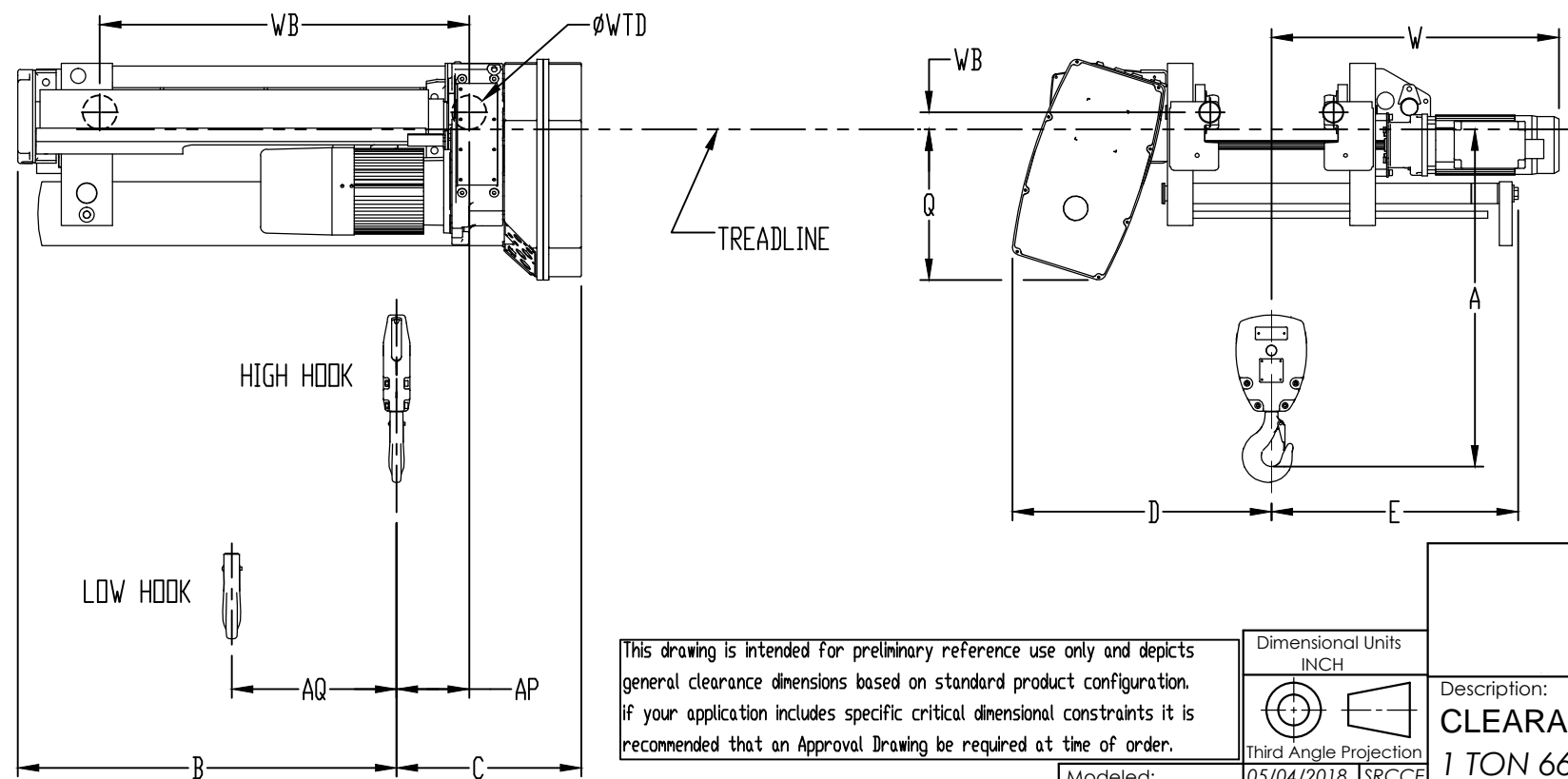

This drawing is intended for preliminary reference use only and depicts general clearance dimensions based on standard product configuration. If your application includes specific critical dimensional constraints it is recommended that an Approval Drawing be required at time of order.

Dimensional Units INCH	
Third Angle Projection	
Modeled:	05/04/2018 SRCCE
Drawn:	05/04/2018 SRCCE
Approved:	
Design Authority:	-
Original project:	-
e:	1:16

2-SPEED

Description:
CLEARANCE DIAGRAM
1 TON 66 FT LIFT S2 REEVING 39 FT/MIN

NOTE:

* DIMENSIONS D, E, AND W ARE SHOWN FOR A BEAM FLANGE WIDTH 8.00 INCHES. THESE DIMENSIONS ARE MEASURED FROM CAD MODELS AND CONSIDERED AS APPROXIMATE VALUES.

ECN	Rev. D
-----	--------

Format	Number:	Sheet
B	YKA-L01-066S239-2	1

ACTUAL FLANGE WIDTH SETTING (IN)	3.25	4.90	5.70	6.90	7.70	8.90	9.85	10.80	12.05	12.80	13.78	14.80	15.75	16.70	17.75	18.70	19.70
MINIMUM HEADROOM DIMENSION "A" (IN)	28.35	29.17	29.57	31.01	31.97	33.42	34.57	35.74	37.28	38.19	39.37	40.59	41.73	42.87	44.13	45.27	46.46

FLANGE ADJUSTMENT RANGES
3.248' - 5.700'
5.701' - 7.700'
7.701' - 9.850'
9.851' - 12.050'
12.051' - 13.780'
13.781' - 15.750'
15.751' - 17.750'
17.751' - 19.700'

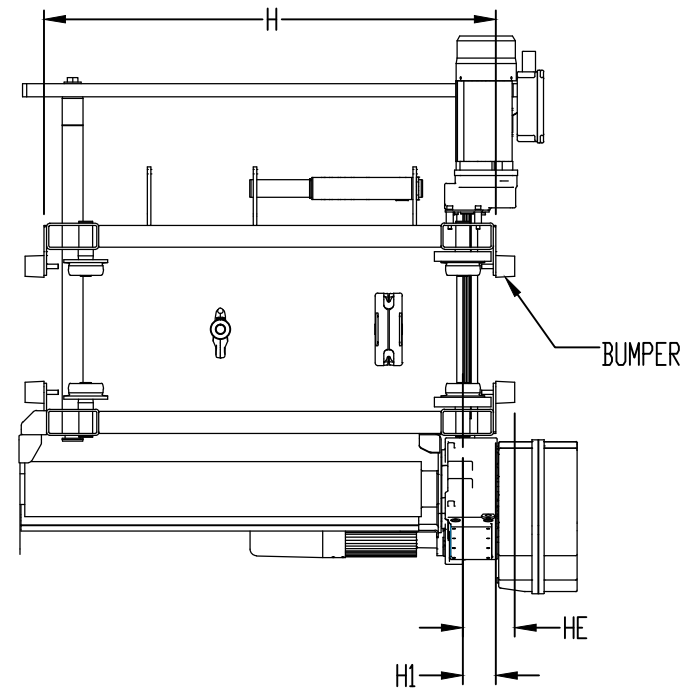

TECHNICAL DATA	
HOIST PLATFORM	GN WIRE ROPE HOIST
HOIST MODEL NUMBER	YKA-L01-066S239-V
RATED LIFT CAPACITY	1 U.S. TON
ACTUAL LIFT DISTANCE	66FT (20.1M)
MAXIMUM LIFTING SPEED	39 FT/MIN (11.9 M/MIN)
REEVING STYLE	2-PART SINGLE-REEVED
HOIST CONTROL TYPE	VARIABLE SPEED
HOIST SUSPENSION TYPE	UNDERHUNG MOTORIZED TROLLEY
TROLLEY TRAVERSE SPEED	80 FT/MIN (24.38 M/MIN)
TROLLEY CONTROL TYPE	TWO-SPEED
TROLLEY BUMPERS	INCLUDED
HOIST DUTY CLASSIFICATION	H4+/M6
OPERATING VOLTAGE	460V/3PH/60Hz
CONTROL VOLTAGE	120VAC
HOIST MOTOR (MAIN) HP	3.90
TROLLEY MOTOR HP	0.6
TROLLEY MOTOR QTY	1
BASE WEIGHT OF HOIST (LBS)	617.12

DIMENSIONAL DATA	
B	34.92 INCH
C	17.30 INCH
D*	23.87 INCH
E*	22.19 INCH
E1*	32.63 INCH
Q	13.89 INCH
W*	26.50 INCH
WTD	3.15 INCH
WB	34.05 INCH
H	40.83 INCH
H1	2.99 INCH
HE	4.69 INCH
XB	1.57 INCH
AP	6.69 INCH
AQ	15.20 INCH

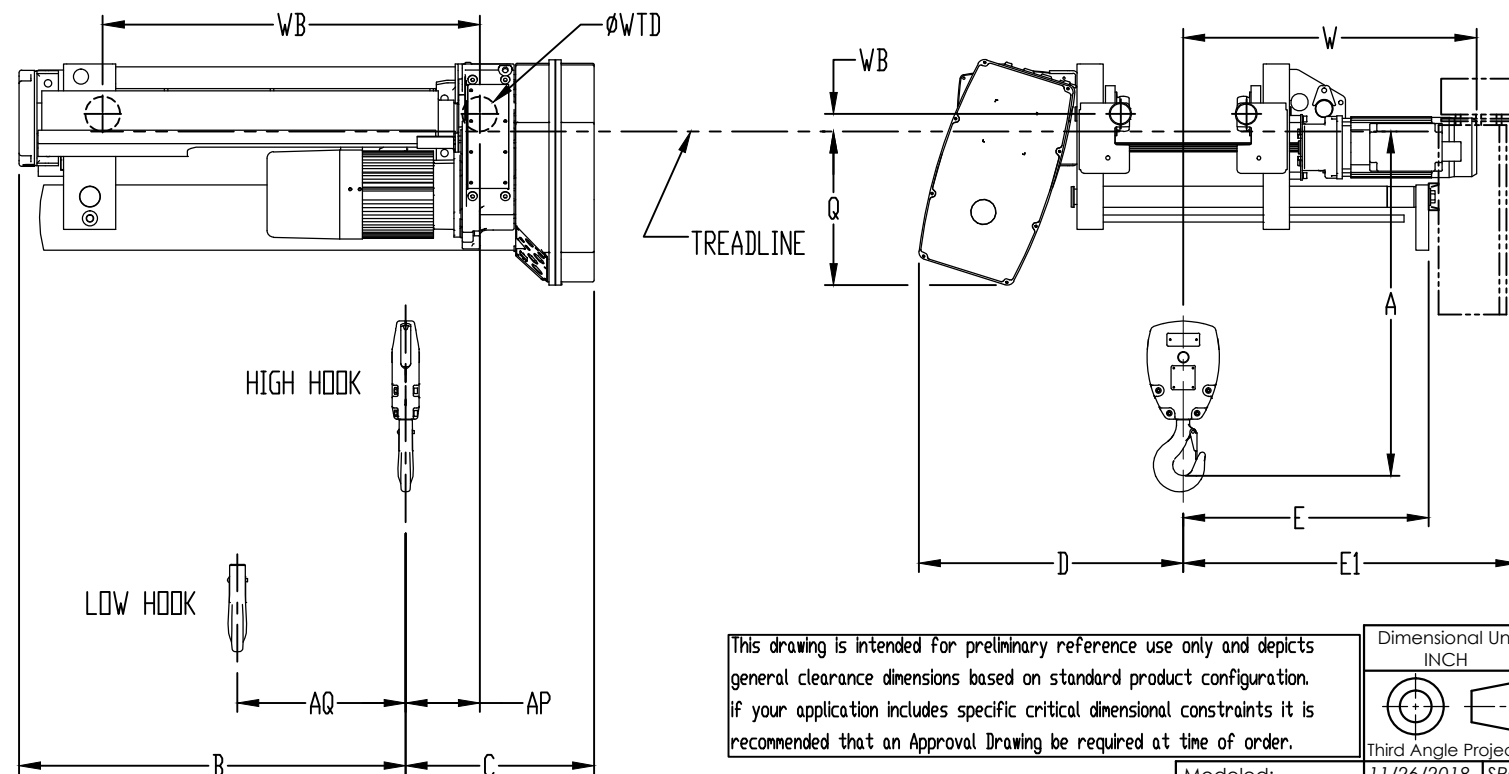

This drawing is intended for preliminary reference use only and depicts general clearance dimensions based on standard product configuration. If your application includes specific critical dimensional constraints it is recommended that an Approval Drawing be required at time of order.

Dimensional Units
INCH
Third Angle Projection

Modeled:	11/26/2018	SRCCE
Drawn:	11/26/2018	SRCCE
Approved:		
Design Authority:		
Original project:		
Original Scale:	1:16	

VARIABLE SPEED

Description:
CLEARANCE DIAGRAM
1 TON 66 FT LIFT S2 REEVING 39 FT/MIN

Format	Number:	Sheet
B	YKA-L01-066S239-V	2

NOTE:

* DIMENSIONS D, E, E1 AND W ARE SHOWN FOR A BEAM FLANGE WIDTH 8.00 INCHES. THESE DIMENSIONS ARE MEASURED FROM CAD MODELS AND CONSIDERED AS APPROXIMATE VALUES.

ECN	Rev.	Description of change	Date	By
-	-	-	-	-
-	-	-	-	-
-	-	-	-	-